

**INDEX**

	<u>Page</u>
0.- Description .....	2
1.- Maintenance .....	2
1.1.- Disassembly .....	2
1.2.- Assembly .....	3
2.- Storage .....	3
3.- Parts list & drawing .....	4
3.1.- DN 50-100 Valves .....	5
3.2.- DN 125-400 Valves .....	6
3.3.- DN 450-600 Valves .....	7
3.4.- DN 700-1000 Valves .....	8



## 0.- DESCRIPTION

The standard double acting pneumatic cylinder consists of:

- Aluminium jacket, cylinder head cover and base cover
- Stainless steel piston rod
- Nitrile coated steel piston

The inlet air pressure should be between 3.5 and 10 Kg/cm<sup>2</sup>.

## 1.- MAINTENANCE



To avoid personal injury or damage to property from the release of process fluid:

- Those in charge of handling and maintenance of the valve must be qualified and trained in valve operations.
- Use appropriate personal protection equipment (gloves, safety shoes, etc).
- Shut off all operating lines to the valve and place a warning sign.
- Isolate the valve completely from the process.
- Release process pressure.
- Drain the process fluid from the valve.

The only maintenance required is to change the seals. This must be carried out in the following way:

### 1.1. – Disassembly:

- 1) Disconnect the supply of air to the cylinder and remove the supply lines. This step must be carried out before any other operation to avoid accidents.
- 2) Remove the gate guards.
- 3) Remove the cylinder assembly by undoing the bolts (12) joining the piston rod (4) to the knife gate (6) and also bolts (10) (nuts n°11 in DN 700-100) joining the base end-cap (3) to the yoke (7).
- 4) Remove any other supports, if any, such as those used to support larger cylinders.
- 5) Once the cylinder has been removed, remove the tie rods (8) between the cylinder head (2) and base end-cap (3) by undoing the nuts (11). (Photo 1)
- 6) Next, remove the cylinder head (2), and then the base end-cap (3).
- 7) Remove the piston and rod assembly (5, 4) from the cylinder (1). (Photo 2)



Photo 1

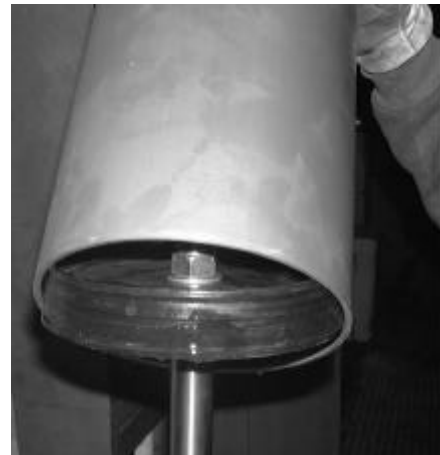

Photo 2

- 8) Remove the piston rod (4) from the piston (5).
- 9) Take the base end-cap (3) and remove the circlip (13). (Photo 3)
- 10) Remove the rod-seal with scraper (14) and carefully push the nylon bush (9) until it is expelled on the other side. (Photo 4)



Photo 3



Photo 4

The cylinder is now totally disassembled.

#### 1.2. – Maintenance and assembly

Once the cylinder is totally disassembled, continue in the following way:

- 1) Examine the seals (14,15,16,17,18) and piston (5) for wear. If necessary, replace them.
- 2) Check the internal surface of the cylinder (1) and the external surface of the piston rod (4). The condition of these surfaces will determine the life of the seals.
- 3) Once all the pieces are cleaned, reassemble by reversing the disassembly procedure.
- 4) Use a Synthetic lubricating grease, based on silicone fluids (consistency, NLGI Grade: 2), during assembly to lubricate the seals and bush (9) mounting, and to coat the piston rod (4) and internal surface of the cylinder (1).

## 2.- STORAGE

For long periods it is recommended to store the valves in a well-ventilated room. Valves should not be exposed to temperatures higher than 30°C, as some soft seal materials can be damaged when exposed to higher temperatures.

If outdoor storage cannot be avoided, cover the valve and protect it from sources of heat or direct sunlight. Provide good ventilation to avoid moisture.

It is recommended to actuate the cylinder 3-4 times before start up, once it has been installed in the pipeline.

### 3.- PARTS LIST & DRAWINGS

There are three models of cylinder for different diameters of valves (see the following diagrams). The component parts of these are listed here:

PART	MATERIAL
1. – Jacket	Aluminium
2. – Cover	Aluminium
3. – Base Cover	Aluminium
4. – Piston Rod	AISI – 304
5. – Piston	Steel + Nitrile
6. – Gate	
7. – Support Plate	
8. – Tie Rod	F – 1110
9. – Bush	Nylon
10. – Bolt	Steel 8.8
11. – Nut	Steel 8.8
12. – Bolt	Steel 8.8
13. – Circlip	Steel
14. – Rod-Seal & Scraper	Steel + Nitrile
15. – ‘O’-Ring	Nitrile
16. – ‘O’-Ring	Nitrile
17. – ‘O’-Ring	Nitrile
18. – ‘O’-Ring	Nitrile
19. – Washer	AE 275-B
20. – Piston Support Plate	Steel
21. – Piston Support Plate	Steel
22. – Piston Ring	Nitrile
23. – Piston Slide Ring	PTFE
23. – Adaptation plate	

3.1.- DN 50-100 VALVES

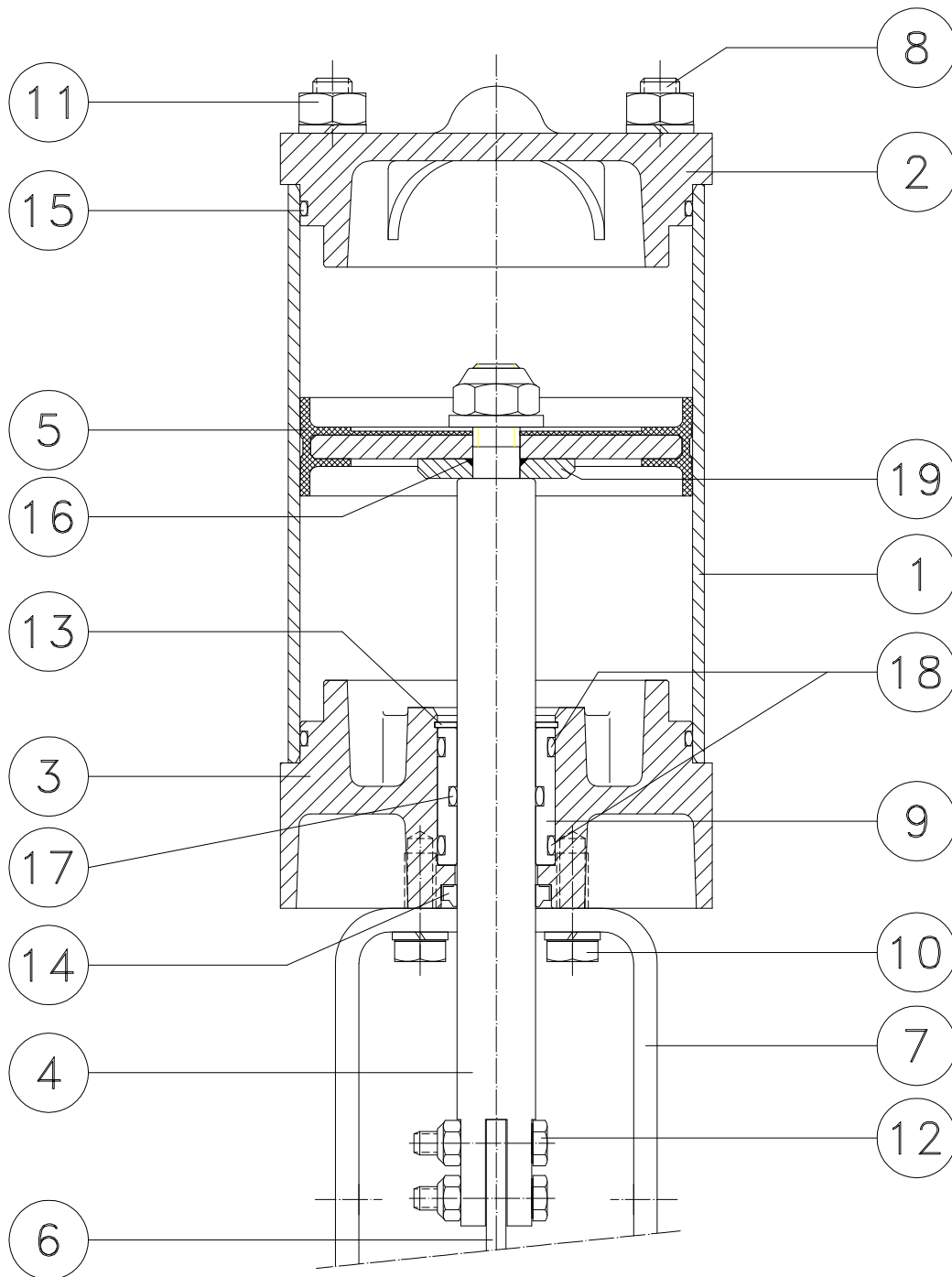

MODEL

# DOUBLE ACTING PNEUMATIC CYLINDER



## 3.2.- DN 125-400 VALVES

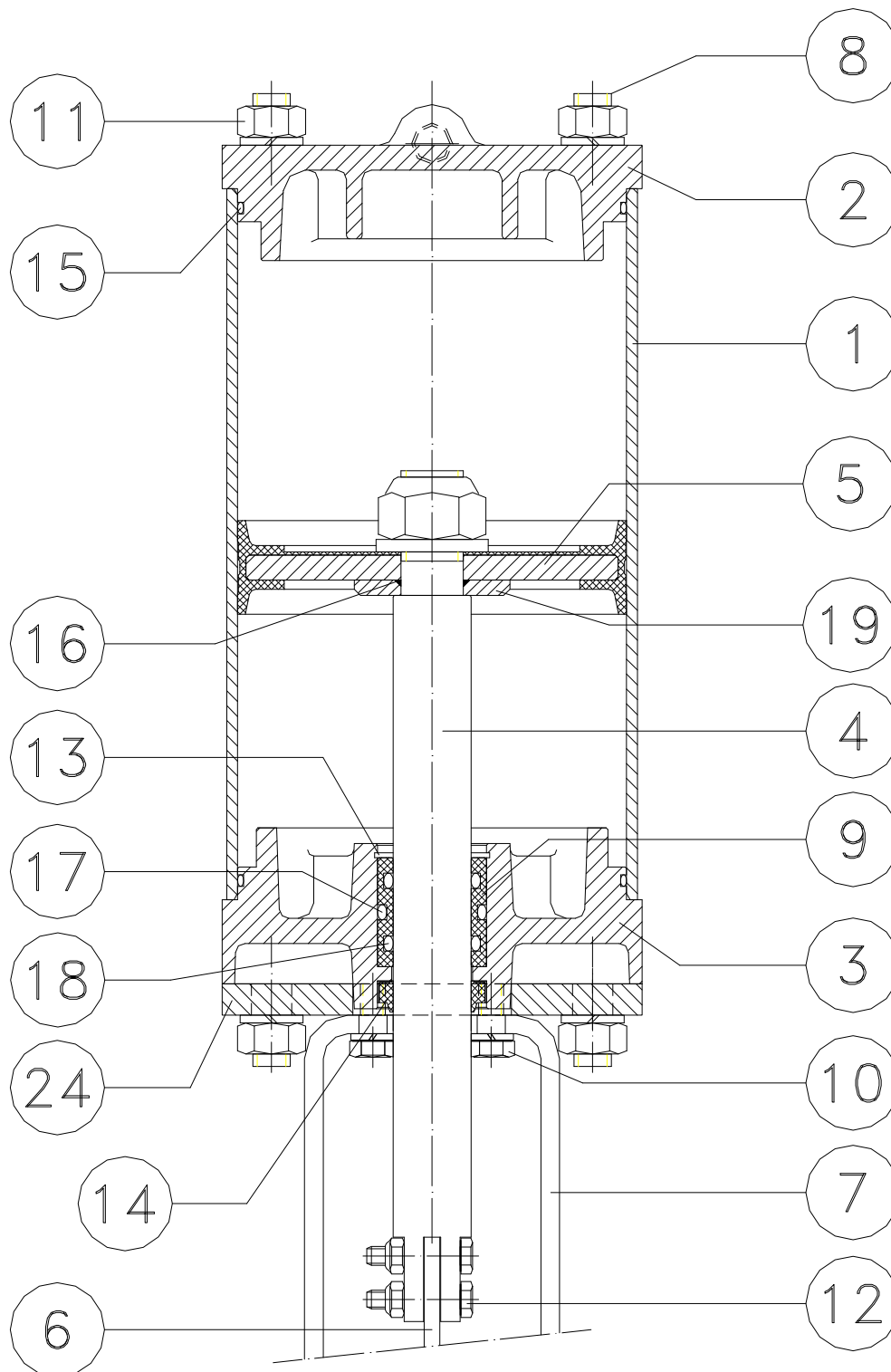

3.3.- DN 450-600 VALVES

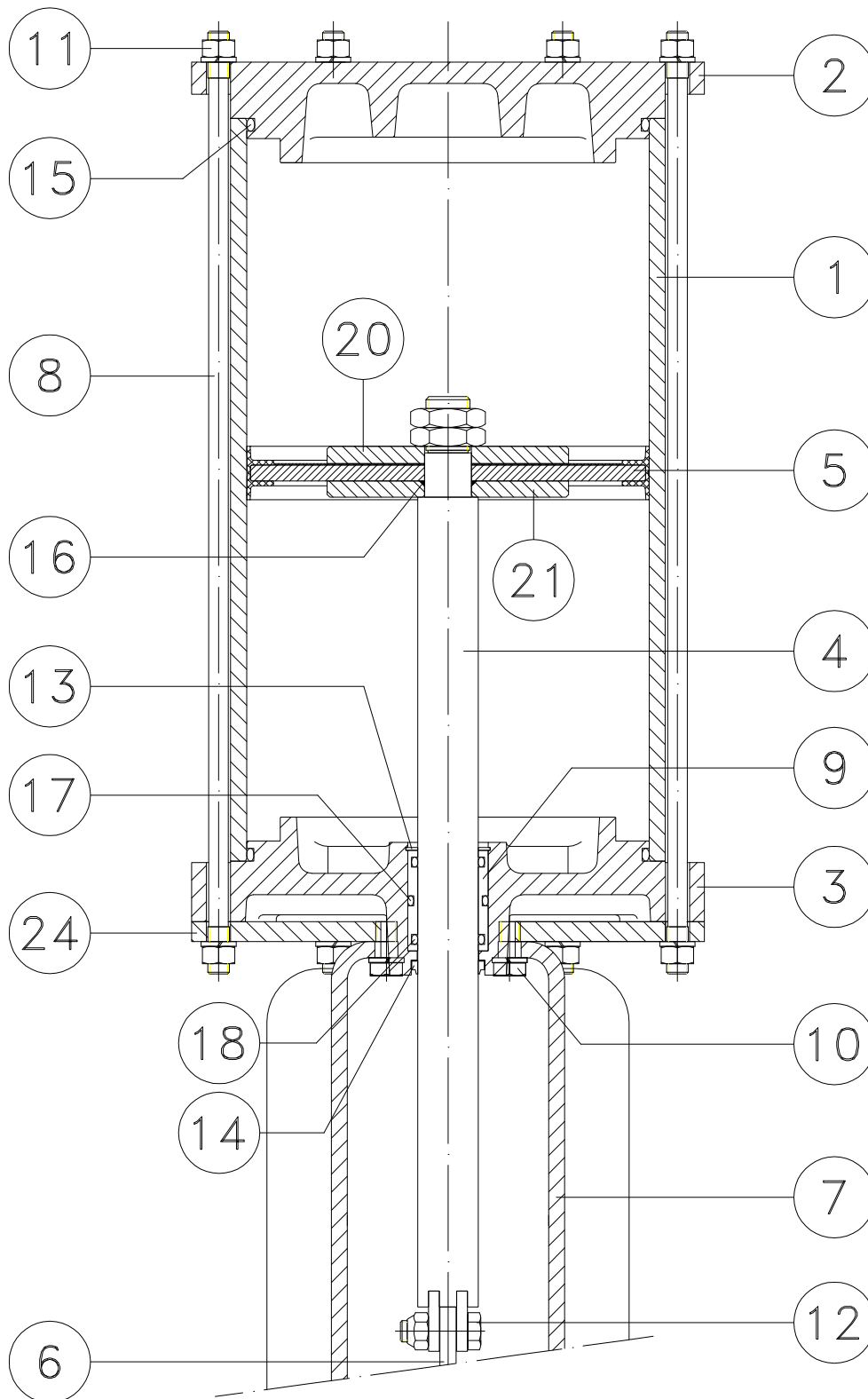

3.4.- DN 700-1000 VALVES

